



## BULK SOLIDS MASS FLOW METER CO-40/60

### TECHNICAL DATA AND DIMENSIONS

The **S-E-G** mass flow meters type CO-40 and CO-60 offers a high precision measurement device for bulk solids combined with easy installation procedure in existing material flows.

Industrial design with a minimum of moving parts, ensure maximum reliability with easy maintenance.

Designed for easy installation with lowest distance between inlet and outlet flanges.

Only cables for mains power and transducer/tachometer connection required to instrumentation.

Optional stainless steel design and turbines for abrasive materials available.

Advanced System T3650 controller with multi-functions such as: Flow indication, Totalising, Regulating, Load out etc.



CAPACITY		CO-40 / 60	
Capacity	min.	2.000 / 3000	kg/h
	max.	40.000 / 60.000	kg/h
		100.000	lit/h
Bulk density	min.	0.3	ton/m <sup>3</sup>
Piece size	max.	10	mm
Material temperature	max.	100	°C

Limits are for guidance, and depend on material specifications.

#### TECHNICAL DATA

Ambient temp.	0 - 40	°C
Material inlet/outlet:	250/300	mm
Accuracy:	0.5 - 1.0	% (depending on capacity and / or material.)
Repeatability:	0.1	%
Drive:	3-phase 220/380 V, 1.5 kW, IP54.	
Load sensor:	S-E-G Torque transducer type ON4-, IP67.	

#### ADDITIONAL

Motor control:	By frequency controller.
Design:	Blue industrial coating as standard, stainless steel SIS 2333 (AISI 304) optional.
Weight:	Approx. 130kg.

0912



Vertrieb, Ersatzteile und Service in Deutschland:  
**INDUK GmbH • Giebel 30 • D-42327 Wuppertal**  
 Tel. +49 (0) 202/ 74 99 870 • Fax +49 (0) 202/ 74 99 877  
 E-Mail: info@induk.de • Internet: www.induk.de

#### S-E-G INSTRUMENT AB

Box 111 43, S-161 11 Bromma, SWEDEN  
 Phone: (+46) 8 764 74 00 Fax: (+46) 8 764 75 00 Internet: www.s-e-g.com  
 VAT: SE556186188001

## DIMENSIONS

All dimensions in mm +/- 5

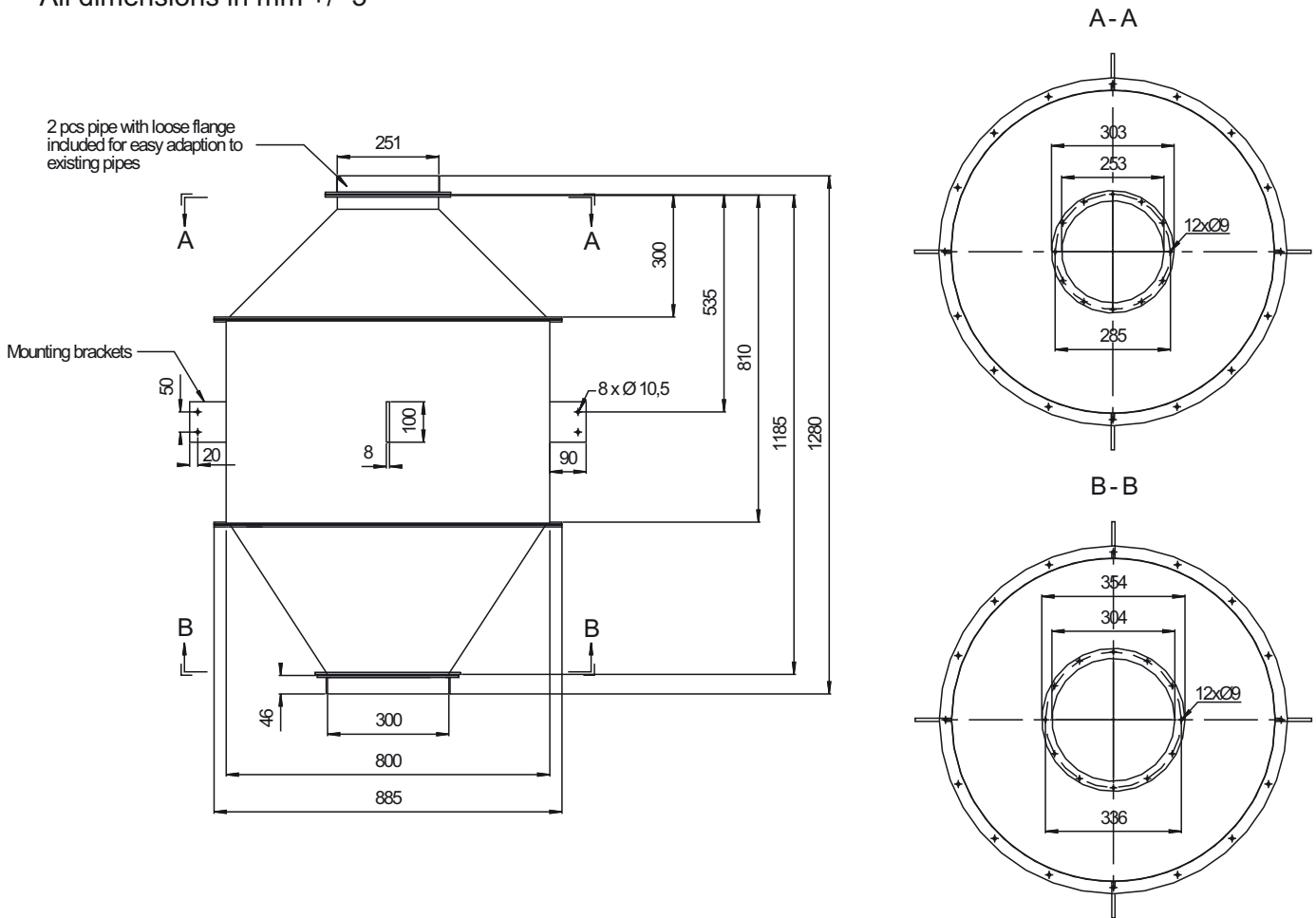

## DESIGNATIONS

Flow meter: CO-40B, -60B  
 Load sensors: ON4-35

Controller: Model T3650. Refer to spec. T42-650E

Frequency controller: CON-150

## OPTIONS

- Turbine for abrasive materials.
- High temperature version.
- Design in Stainless steel SIS2333 (AISI 304).
- By-pass tube.

